

Daikin Rooftops & VRV

TIM TOCKET
DAIKIN

HVAC Distributors Dealer Meeting Daikin Light Commercial and VRVS Equipment Overview



Light Commercial Package Line-Up



	Efficiencies	
	Standard	High
Capacities	3 - 25 Ton Gas Electric and AC 3 - 10 Ton Heat Pump	3 - 12.5 Ton Gas Electric and AC 3 - 6 Ton Heat Pump
Ratings	13.4 SEER2/11 EER2 Up to 11.2 EER/ 15.5 IEER	16.4 SEER2/12.1 EER2 Up to 12.4 EER/ 17 IEER
Stages	3 - 5 Ton 1 Stage 6 - 25 Ton 2 Stage	3 - 12.5 Ton 2 Stage
Voltages	208/230 1 and 3 Phase, 460, 575 Volt	



OUTSTANDING WARRANTY



Light Commercial Package Models



	Models	
	R410a	R32
AC	DFC – Standard Efficiency DRC – High Efficiency	DSC – Standard Efficiency DHC – High Efficiency
Gas Electric	DFG – Standard Efficiency DRG – High Efficiency	DSG – Standard Efficiency DHG – High Efficiency
Heat Pump	DFH – Standard Efficiency DRH – High Efficiency	DSH – Standard Efficiency DHH – High Efficiency



OUTSTANDING WARRANTY



This is ok? right



Key Features – Commercial Packaged Units

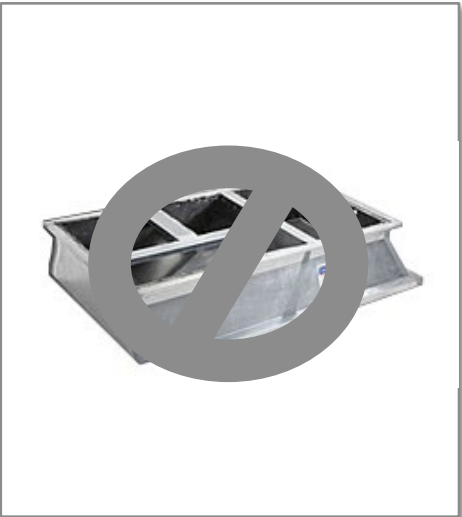

**Fits many curbs
without curb adapter**



**Direct-Drive
Supply
Fan Blowers**



**5mm smart coil
coil technology in
outdoor coils**

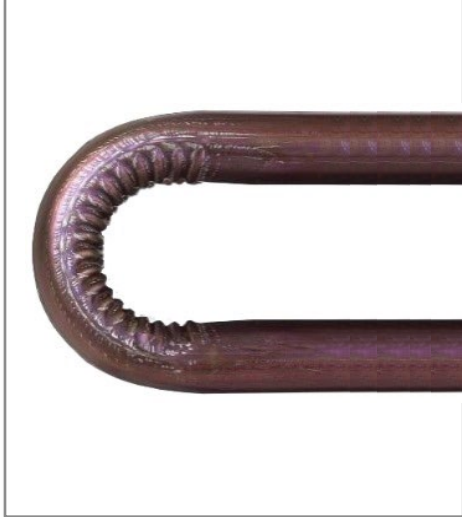





**Wrinkle bend
technology in gas
heat exchangers
in G/E units**



**Outstanding
warranty**

Warranty Comparison

					
Parts	5 years	1 year (3 yr some cond)	1 year (3 yr some cond)	1 year	1 year
Compressor	5 years	5 years	5 years	5 years	5 years 1 yr 20-25 t
Heat Exchanger	20 years	10 yrs std HX 15 yrs SS HX	10 yrs std HX 15 yrs SS HX	10 yrs std HX 20 yrs SS HX	5 years 1 yr 20-25 t

Real Value, Everyday!

Designed for New Construction and Ease of Replacements



Daikin Light Commercial R-32 Rooftop Units - Curb Fit Cross Reference Guide

If replacing 7½ -12½ Ton Daikin DC series with Daikin DS*/DH*series, please contact your Sales Rep for curb adaptor details.*

Daikin High Efficiency

G/E Pkg	AC Pkg	HP Pkg
DHG036 - 072	DHC036 - 072	DHH036 - 072

Daikin Standard Efficiency

G/E Pkg	AC Pkg	HP Pkg
DSG036 - 072	DSC036 - 072	DSH036 - 060

Fits Existing Curb¹

Carrier

G/E Pkg	E/E Pkg	H/P Pkg
48DJ(D,E,F)004 - 007	50DJ004 - 007	50QJ004 - 006
48GJ(D,E,F)006	50GJ006	50HEQ003 - 006
48HE(D,E,F)004 - 006	50HE004 - 006	50HEQ004 - 006
48HJ(D,E,F)004 - 007	50HJ004 - 007	50LJ004 - 006
48HM(D,E)007	50HM007	50TC004 - 007
48LJ(D,E,F)004 - 007	50LJ004 - 007	50TF006 - 007
48TC(D,E,F)004 - 007	50TC004 - 007	50TJ004 - 007
48TF(D,E,F)006 - 007	50TF006 - 007	50HCQ 004 - 006
48TJ(D,E,F)004 - 007	50TJ004 - 007	
48HC 004 - 006	50HC 004 - 006	

Bryant

G/E Pkg	E/E Pkg	H/P Pkg
581A*V036 - 072	551A*X036 - 072	549B*X036 - 072
581B*V036 - 072	551B*X036 - 072	548C*X036 - 060
580C*V036 - 072	558C*X036 - 072	548D*X036 - 072
580D*V036 - 072	558D*X036 - 072	548F*X036 - 072
580F*V036 - 072	558F*X036 - 072	548J*04 - 07
580J*04 - 07	558J*04 - 07	

ICP Brands

G/E Pkg	E/E Pkg	H/P Pkg
PGE036 - 072	PAE036 - 072	PHE072
PGH036 - 072	PAH036 - 072	PHH036 - 072
PGS072	PAS072	PHS072
RGS036 - 072	RAS036 - 072	RHS036 - 072

G/E Pkg	AC Pkg
DHG090 - 150	DHC090 - 150

G/E Pkg	AC Pkg	HP Pkg
DSG090 - 150	DSC090 - 150	DSH090 - 120

Fits Existing Curb¹

G/E Pkg	E/E Pkg	H/P Pkg
48DJ(D,E,F)008 - 014	50DJ008 - 014	50QJ008 - 012
48GJ(D,E,F)008 - 012	50GJ008 - 012	50HJQ008 - 012
48HJ(D,E,F)008 - 014	50HJ008 - 014	50LJQ008 - 012
48LJ(D,E,F)008 - 014	50LJ008 - 014	50TCQ008 - 09
48TC(D,E,F)008 - 014	50TC008 - 014	50TFQ008 - 012
48TF(D,E,F)008 - 014	50TF008 - 014	50TJQ008 - 014
48TJ(D,E,F)008 - 014	50TJ008 - 014	50HCQ 007 - 009
48HC 007 - 012	50HC 007 - 012	

G/E Pkg	E/E Pkg	H/P Pkg
581A*V090 - 150	551A*X090 - 150	549B*X090 - 120
581B*V090 - 150	551B*X090 - 150	548C*X090 - 120
580B*V090 - 150	558B*X090 - 150	548D*X090 - 120
580C*V090 - 150	558C*X090 - 150	548F*X090 - 120
580D*V090 - 150	558D*X090 - 150	548J*08 - 09
580F*V090 - 150	558F*X090 - 150	
	558J*08 - 012	

G/E Pkg	E/E Pkg	H/P Pkg
PGE090 - 150	PAE090 - 150	PHE090 - 120
PGH090 - 150	PAH090 - 150	PHH090 - 120
PGS090 - 150	PAS090 - 150	PHS090 - 120
RGS090 - 150	RAS090 - 150	RHS090 - 102

- List available on DaikinAC.com Light Commercial



¹ It is the responsibility of the installing contractor to review the dimensional drawings for the new Daikin Series equipment (see below) and confirm that it is an exact fit for the existing unit curb. Daikin is not responsible for providing additional materials and/or curb adaptors UNLESS otherwise quoted.

Designed for New Construction and Ease of Replacements



Original unit being lifted off



Daikin unit on crane



Daikin unit installed on original roof curb without a curb adapter

No Curb Adapter Required for Base and High Efficiency Models

when Changing Out Many
3 – 12 ½ ton Carrier/Bryant/newer ICP RTU's

Key Factory Installed Options are now released

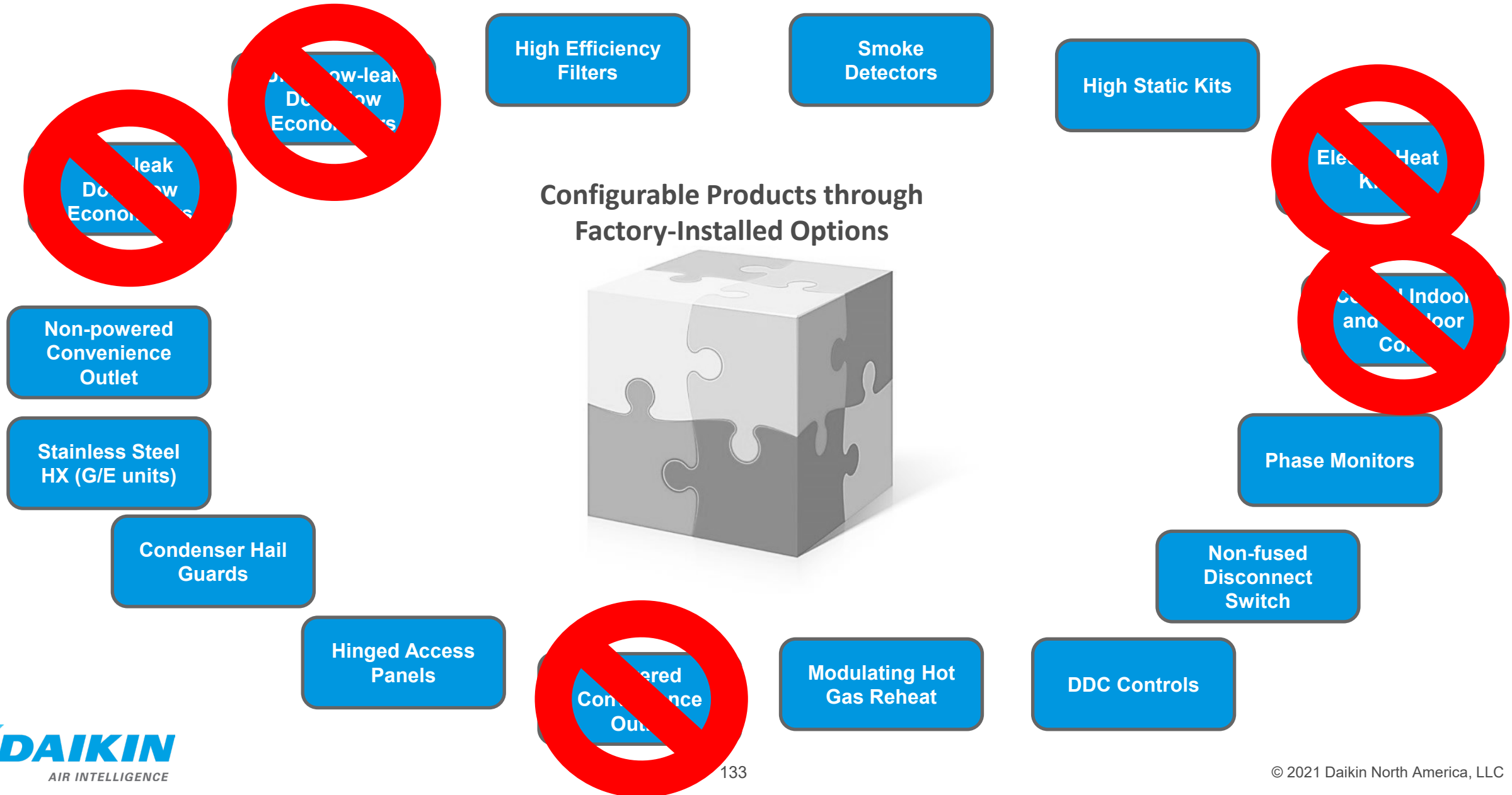

Key Field Installed Options

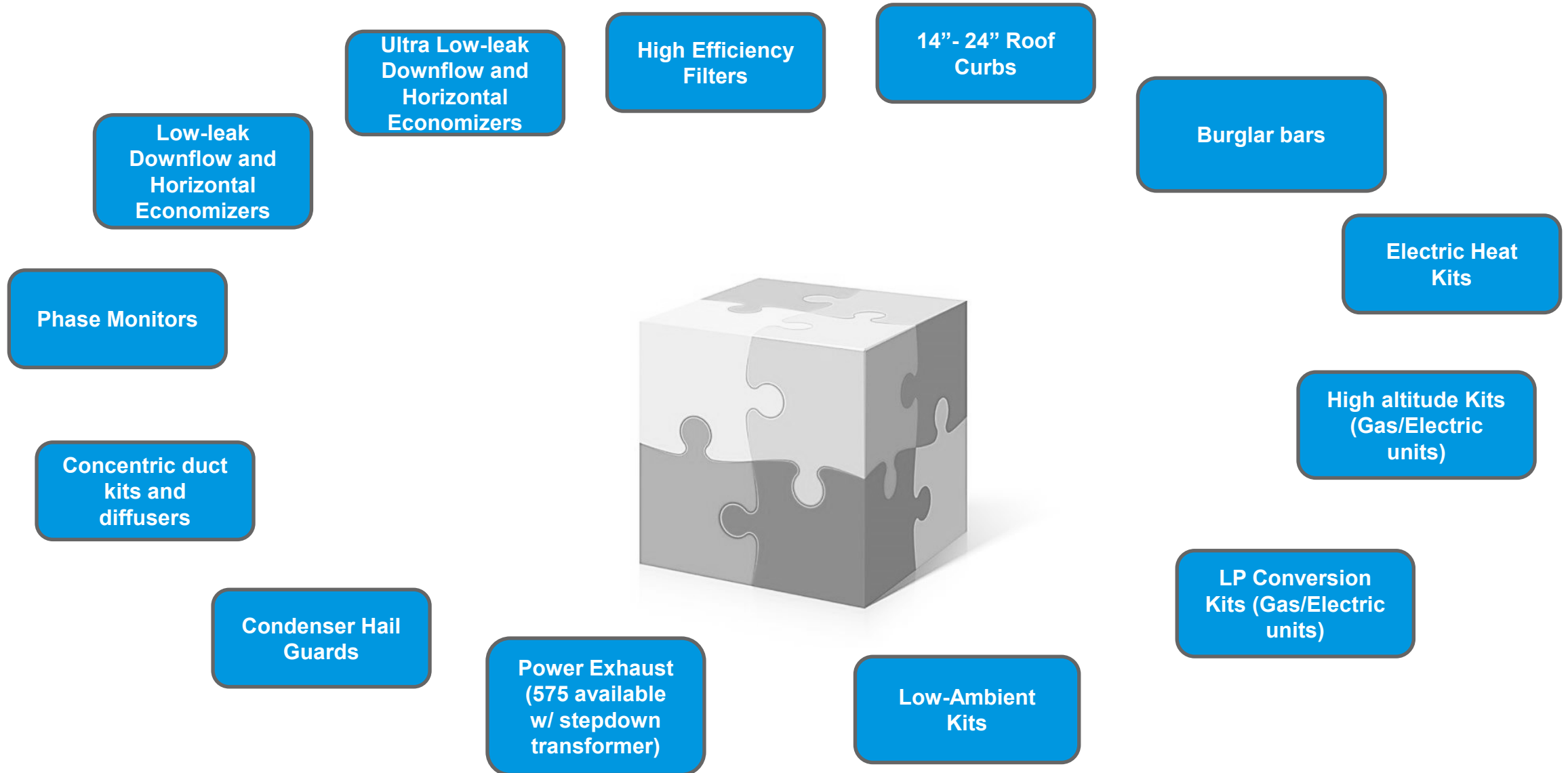

HVAC Distributors flatbed jobsite deliveries



Daikin Comfort Technologies Flatbed Shipping for Jobsite Deliveries



- Improved packaging process
- Added single-wall cardboard (stretch wrapped) around the units



R32 Sensor Locations

Small Chassis AC/GE/HP 3-6T Medium Chassis AC/GE/HP 7.5-12.5T Large Chassis AC/GE 15-25T

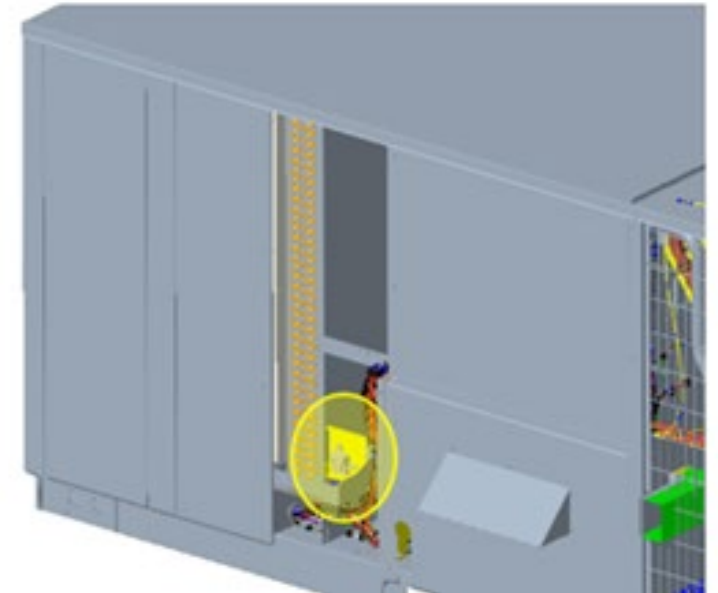
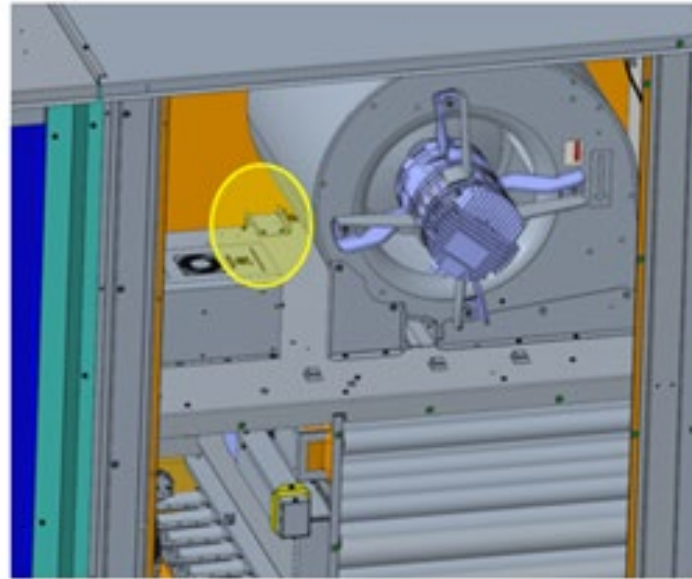
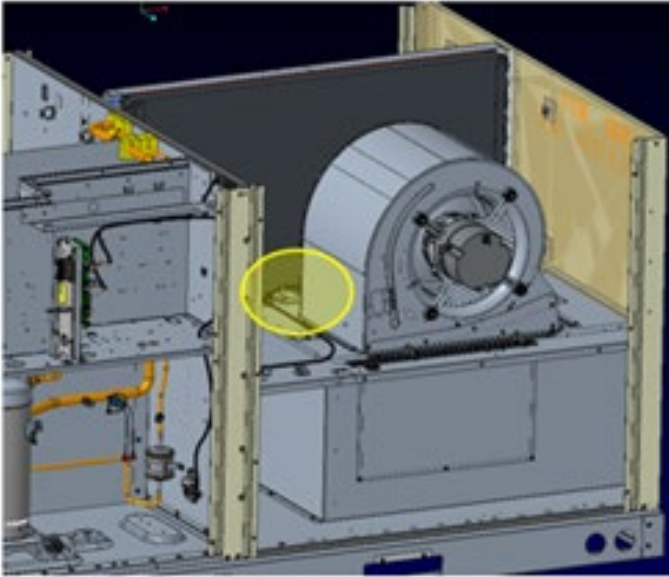

Light Commercial Controls



Thermostats with advanced features

- Wi-Fi and Daikin Skyport App
 - SkyPort app offers voice control with Amazon Alexa
- OpenADR 2.0b certified with Skyport Cloud
- Thermostat with BACnet capability
- New generation iLINQ DDC controls



works with
amazon alexa

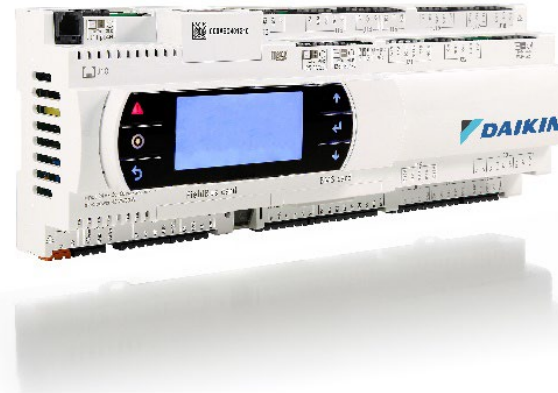

BACnet
International

Thermostats with WiFi Connectivity and Skyport™ Cloud



ColorTouch Thermostat



Premium Mini



Premium Series Thermostats

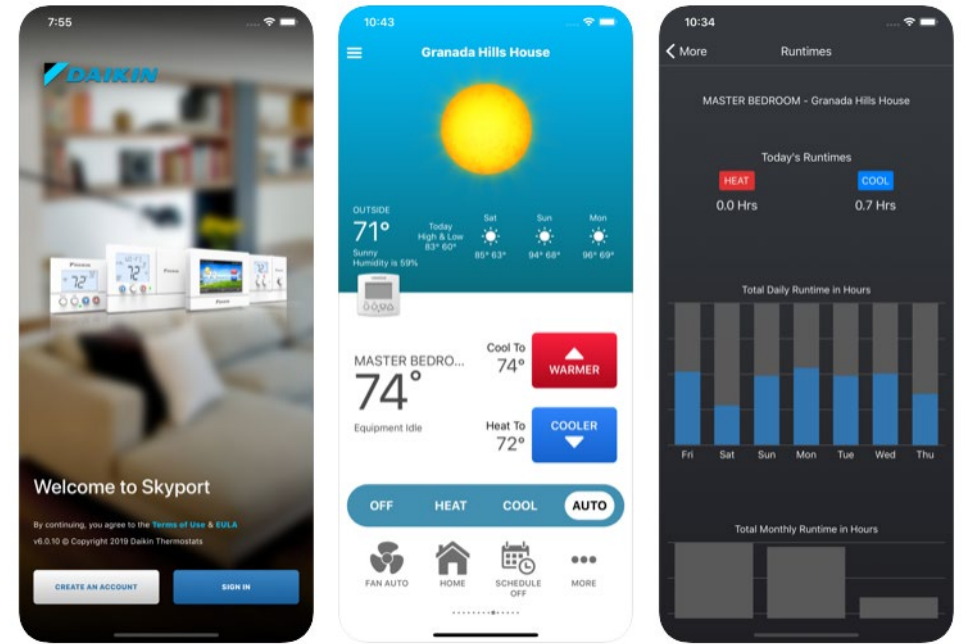

Daikin Skyport
Skyport Labs
Free



- Title 24 Compliant
- OpenADR 2.0b certified with Skyport
- Application Program Interface (API)

BACnet Thermostats

- The **App Stat** combines the power of a space-mounted equipment controller with the convenience of a built-in temperature sensor.
- The controllers include factory supplied programs for the following applications:
 - AC and Gas/Electric units
 - Heat pump units
- Supports stand alone operation
- New or retrofit applications
- Network ready native BACnet controller.



Low Cost alternative to DDC controller

- BACnet native
- USB connector for software connection
- Built-in display
- Integrate into BMS or operate as stand-alone digital system

Communication



- LonWorks
- BACnet MS/TP
- BACnet IP

Web Interface Software

- Set-up & commissioning
- Complete access to all control points
- Trend logging capabilities

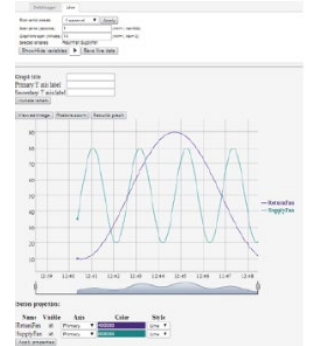

Graphic Terminals



- LCD backlit display
- Graphics management
- Six button keypad

Sensors



- Analog and digital temperature and temperature/humidity
- CO2 sensor

Note: can connect to regular low voltage 24V thermostats. Both for new construction and replacements jobs.

iLINQ DDC Controls



Daikin iLINQ™

11:35 AM
09/05/19

Home User

- RTU_01
- Parameters
- Settings
- Alarms List
- Network
- Info

Schedule Mode	TStat	Space CO2	774 PPM	Heating Lockout	
HVAC Mode	Vent	Outdoor Temperature	69.2 °F	Economizer Enable	true
Stage	NONE	Outdoor Humidity	36 %RH	Blower Speed	50%
Space Humidity	39 %RH	Cooling Lockout			

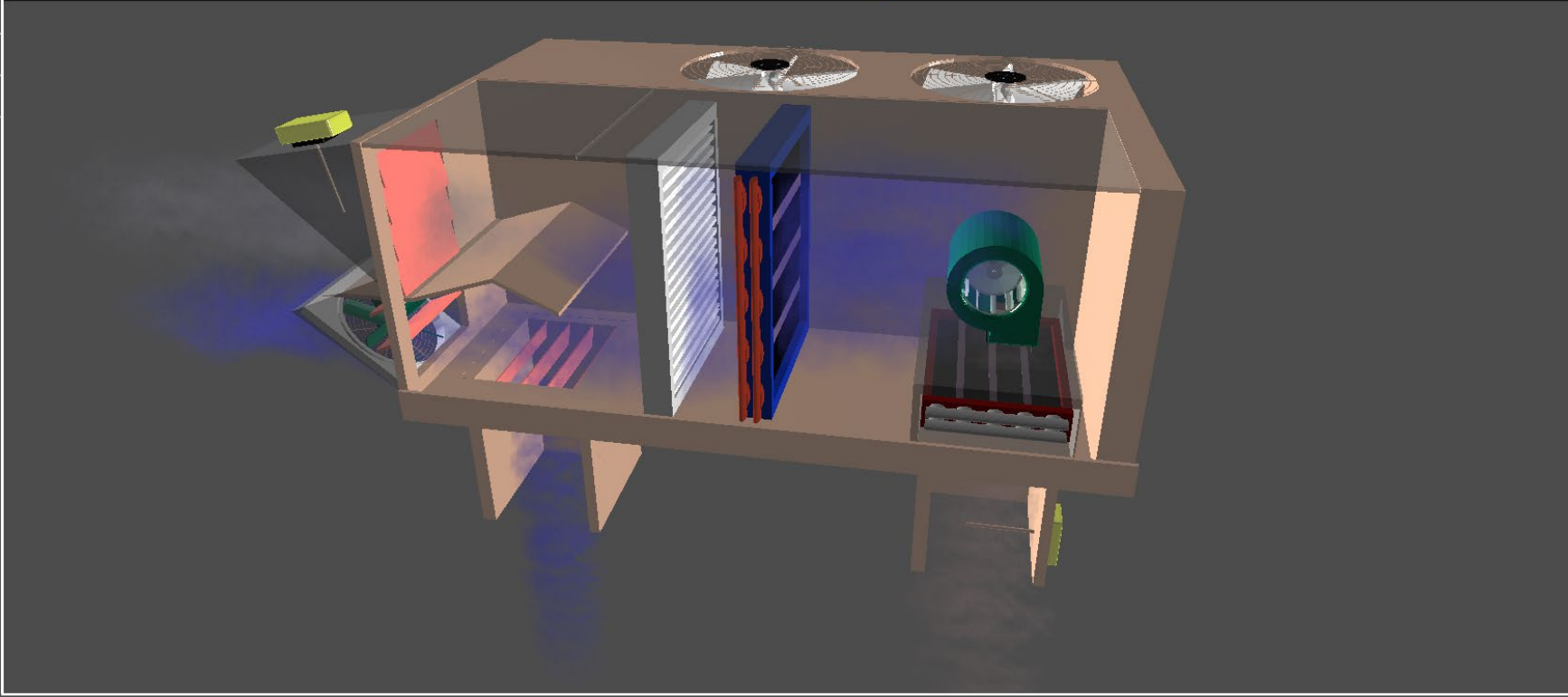



Web 1087



Daikin iLINQ™

11:37 AM
09/05/19



RTU_01

- Status
- Schedule
- Test/Balance
- Live Trend Data
- Historical Trend Data
- Blower Motor Info
- Onboard Display

Parameters

Settings

Alarms List

Network

Info

Unit Status

Schedule Mode: **T-Stat**
HVAC Mode: **Vent**

Cooling Load	Heating Load	Lead Compressor	
0 %	0 %	1&2	
Space Temperature	Active Cooling Setpoint	Active Heating Setpoint	Space Setpoint Adjust
57.2 °F	82.0 °F	60.0 °F	-0.5 °F
Space Humidity	Space Humidity Setpoint	Space Enthalpy	Space CO2
39 %RH	65 %RH	17.8 btu/lb	774 ppm
Outdoor Temperature	Outdoor Humidity	Outdoor Enthalpy	
69.2 °F	36 %RH	22.4 btu/lb	
Supply Temperature	Active Supply Temperature Setpoint	Economizer Feedback	
73.8 °F	70.0 °F	10 %	
Head Pressure 1	Head Pressure 2	Suction Pressure 1	Suction Pressure 2
279 psig	280 psig	196 psig	129 psig

Monitor

Emergency Shutdown	Compressor 1 Pressure Switch
Compressor 2 Pressure Switch	Compressor 3 Pressure Switch
Compressor 4 Pressure Switch	Defrost Switch C1
Defrost Switch C2	Furnace Feedback 1
Furnace Feedback 2	G
Y1	Y2
W1	W2

Lockout/Enables

Cooling	Heating
Heat Pump Heating	Dehumidification
Economizer	Defrost

Control

Blower Stage 1	Blower Stage 2
Heating Stage 1	Heating Stage 2
Reversing Valve 1	Reversing Valve 2
Exhaust Fan	Purge Valve
Compressor 1	Compressor 2
Compressor 3	Compressor 4
Condenser Fan 1	Condenser Fan 2
Alarm Output	
Economizer Position	Blower Speed
5 %	50 %
SCR Heat Output	Reheat Valve Position
0 %	0 %

Web 1087

iLINQ DDC Controls



Room Temperature



Room Temperature with humidity



Outside Air Temperature



Outside Air Temperature with humidity



Duct Temperature Sensors



Duct Co2 Sensor



Space Co2 Sensor



Duct Humidity Sensors

iLINQ

Applications

- Commercial buildings with BMS/BAS systems in place.
 - Schools
 - Strip mall retail stores
 - Clinics
- Buildings with airflow modulation requirement.
- Systems requiring BacNET or LonWorks connectivity.
- Remote access and Trend logging.

Highlights

BacNET native controls

- Easy connectivity to control systems
- LonWorks capability
- Multiple optional sensors offering

Airflow control

- Exact airflow adjustment
- Up to 5 different airflows available

Modulating Hot Gas Reheat MHGRH



- Available for 410A DRC and DRG High Efficiency Rooftop Units
R-32 DHC and DHG High Efficiency Rooftop Units will also be available (soon)
- To be used with Daikin iLINQ DDC controls and MHGRH module
- Microchannel HGRH Coil
- Leaving air temperature at a neutral condition to avoid overcooling the space

MHGRH Operation

Using a space temperature and humidity sensor in conjunction with the Daikin iLINQ Controller and Reheat Module, the unit can initiate a Dehumidification Mode as the space humidity rises above set-point.

Normal Cooling Heat Gas Valve (HGV) closed, Purge Valve open.

In cooling mode, the unit can operate with one or two compressor stages. The cooling only system operation is the same as a typical refrigerant cycle.

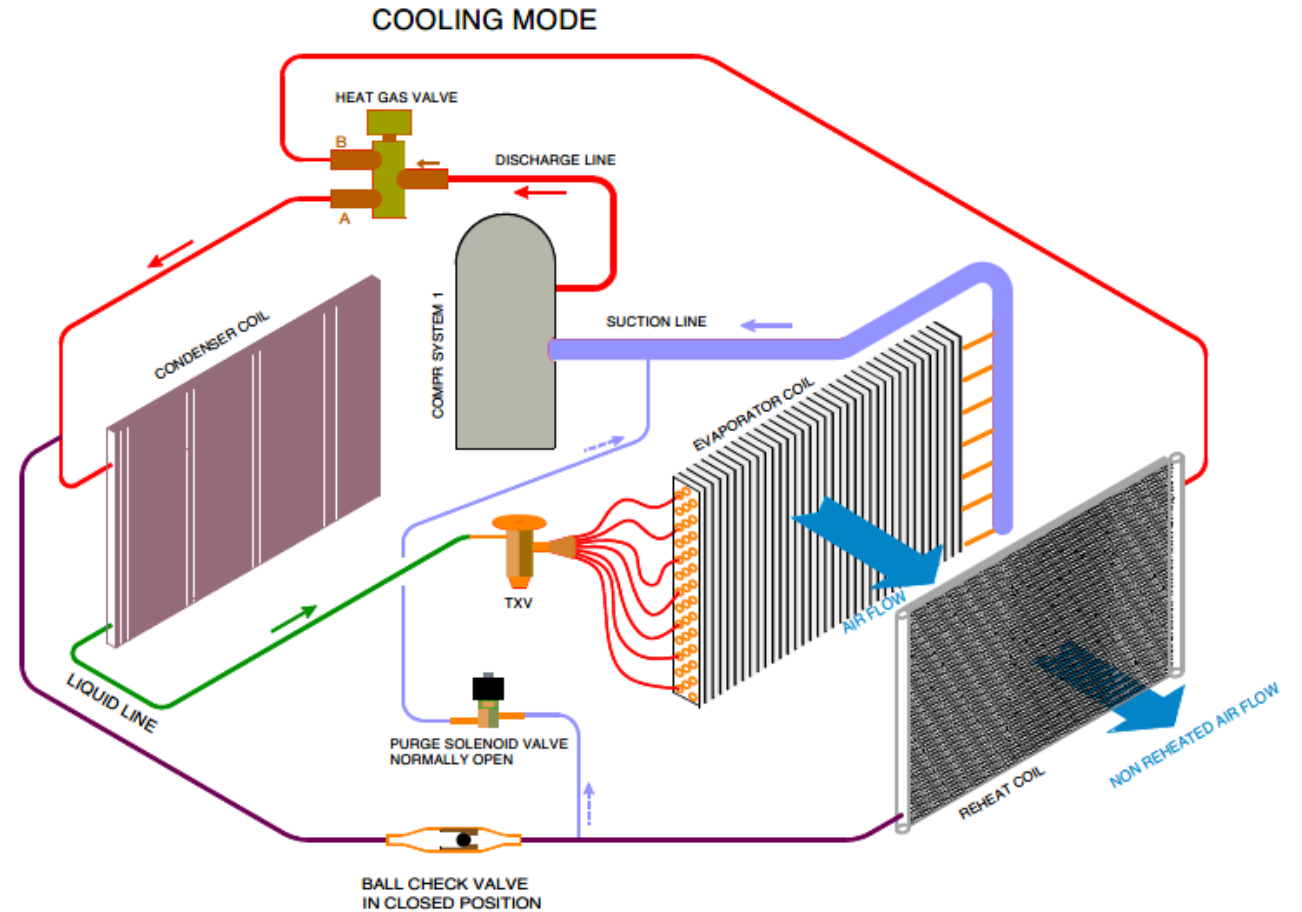

MHGRH Operation

Dehumidification Heat Gas Valve (HGV) open, Purge Valve closed.

If the space temperature is satisfied, but the space humidity is high, the unit will initiate Dehumidification Mode. One or two compressor stages, as allowed by the system, will stage on. The supply air will be regulated at a neutral temperature setting by modulating the HGV to extend operation of the evaporator coils for dehumidification. As space conditions change, the supply air temperature set-point is reset to maintain occupant comfort and optimize compressor operation.

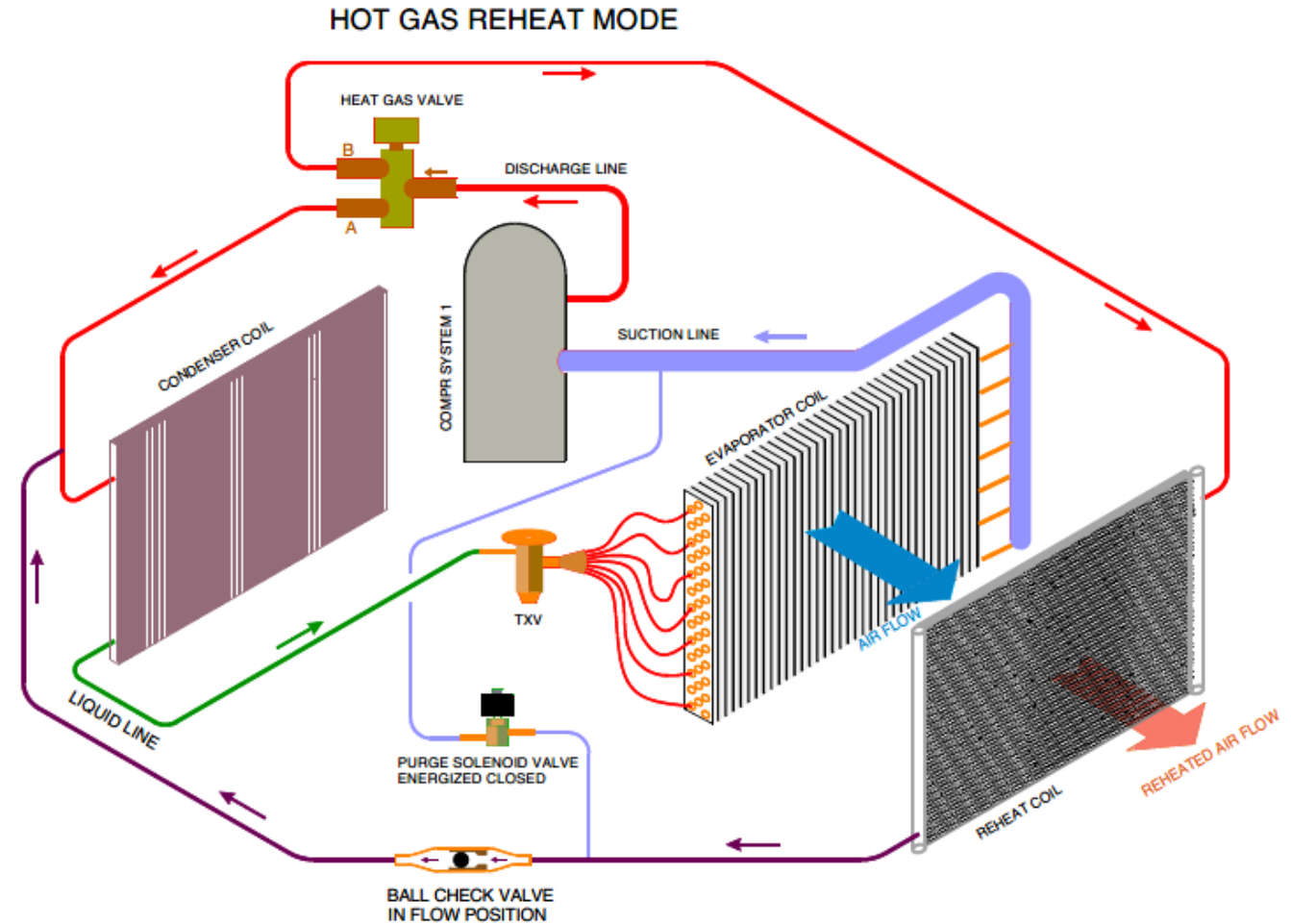

Hot Gas Reheat

Applications

- Commercial buildings with humidity control requirements.
 - Medical buildings
 - Storage buildings
 - Assisted living
- Locations with high humidity concentration.
- Microchannel coil for higher performance

Highlights

Neutral air discharge

- No overcooling or overheating of the space
- Second stage to satisfy space requirements

Low airflow performance

- Lower noise
- High humidity reduction
- Designed for comfort cooling

R32 – VRV S



DAIKIN
VRV



Environmentally Sustainable



A2L Refrigerant Transition – Design Considerations

Releasable Refrigerant Charge - MREL

- † Quantity of refrigerant that could be released by equipment into a room if a leak were to happen

- † Varies based on: unit charge, pipe size and piping length

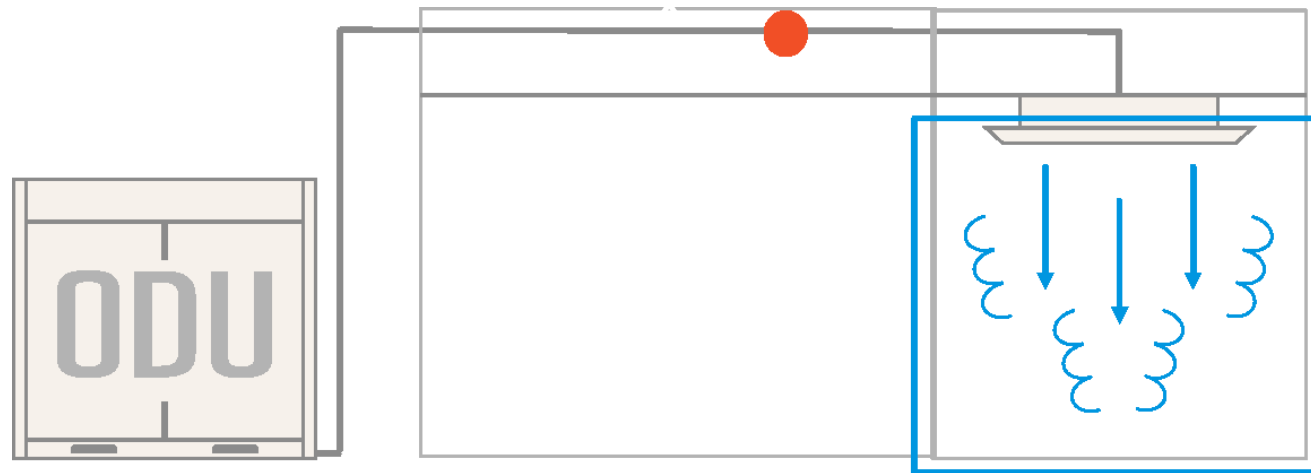

A2L Refrigerant Transition – Design Considerations

Effective Dispersal Volume Charge

† How much charge can be released into the room while still keeping it below RCL

† **EDVC** = LFL X Focc X Veff X CF

- LFL – Lower Flammability Limit
- Focc – 0.5 for institutional; 1 for all others
- Veff – Effective volume that refrigerant can disperse
- CF – 0.25*

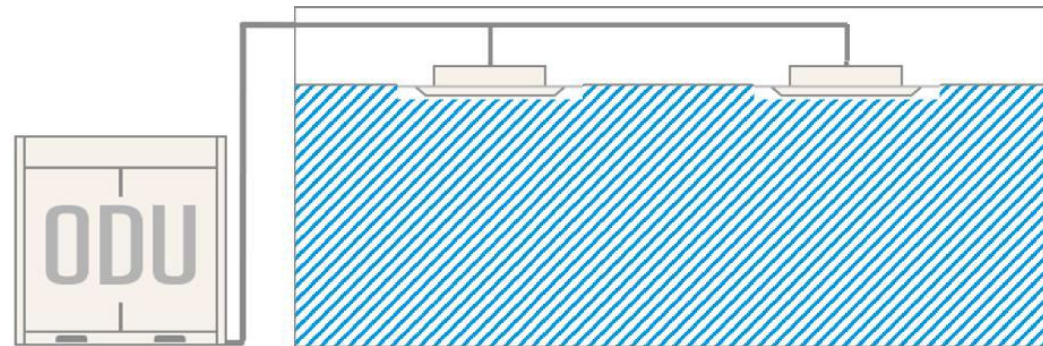

A2L Refrigerant Transition – Design Considerations

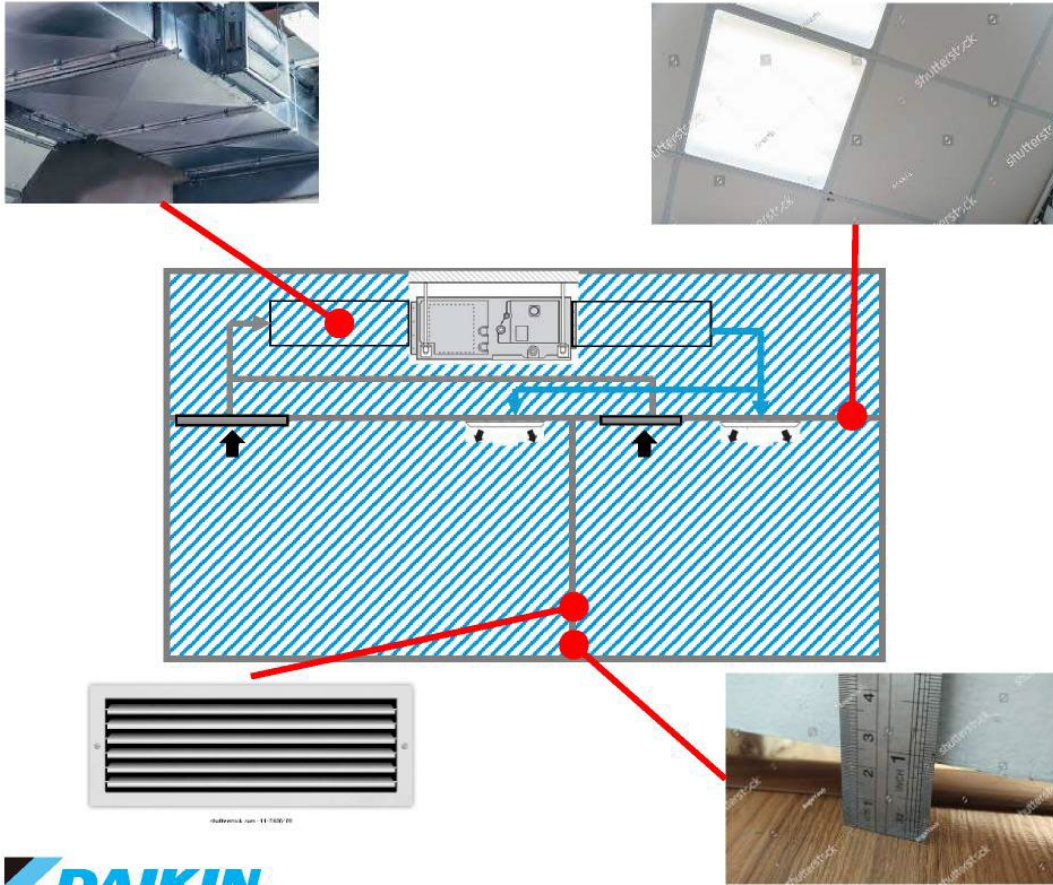

EDVC – Connected Spaces

⊕ If two spaces are connected, then EDVC can be the combined volume

⊕ Examples of ways to potentially connect spaces

- Transfer grilles
- Door undercuts
- Permeable ceilings
- Connected ductwork
- Plenums



A2L Refrigerant Transition – Design Considerations

Natural Ventilation

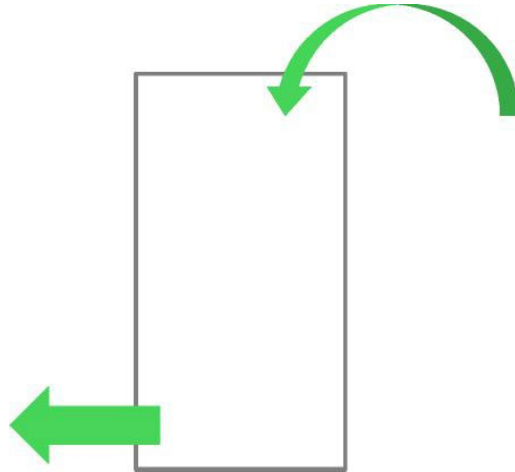

ASHRAE defines the minimum opening for Natural Ventilation:

- † Max height from bottom
- † Min size of opening

Mechanical Ventilation

† For cases where M_{rel} is higher than EDVC and is needed in addition to other mitigation measures

† Makeup air required, minimum ventilation specified per ASHRAE 15 guidelines

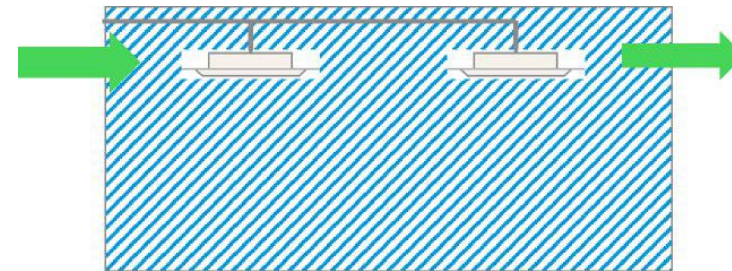

A2L Refrigerant Transition – Design Considerations

Circulation

- Code allows for double the EDVC (from 0.25 to 0.5 correction factor) since the air is being circulated around the space
- Full airflow mode required if leak is detected

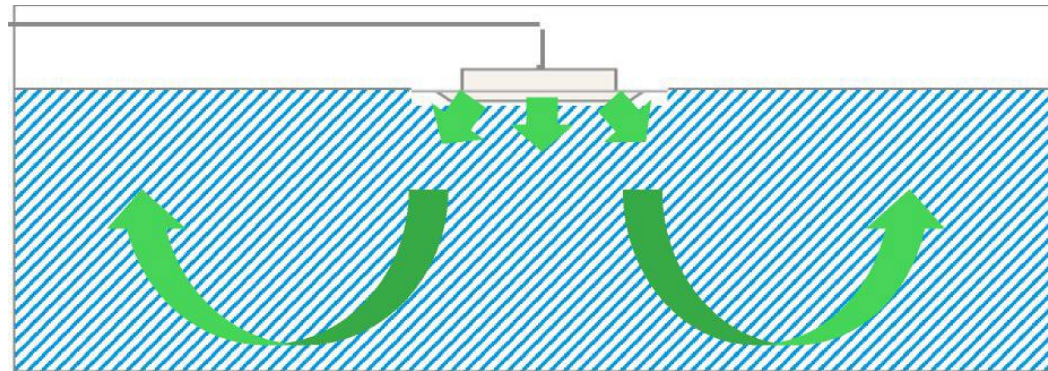

Introducing R32 VRV Line

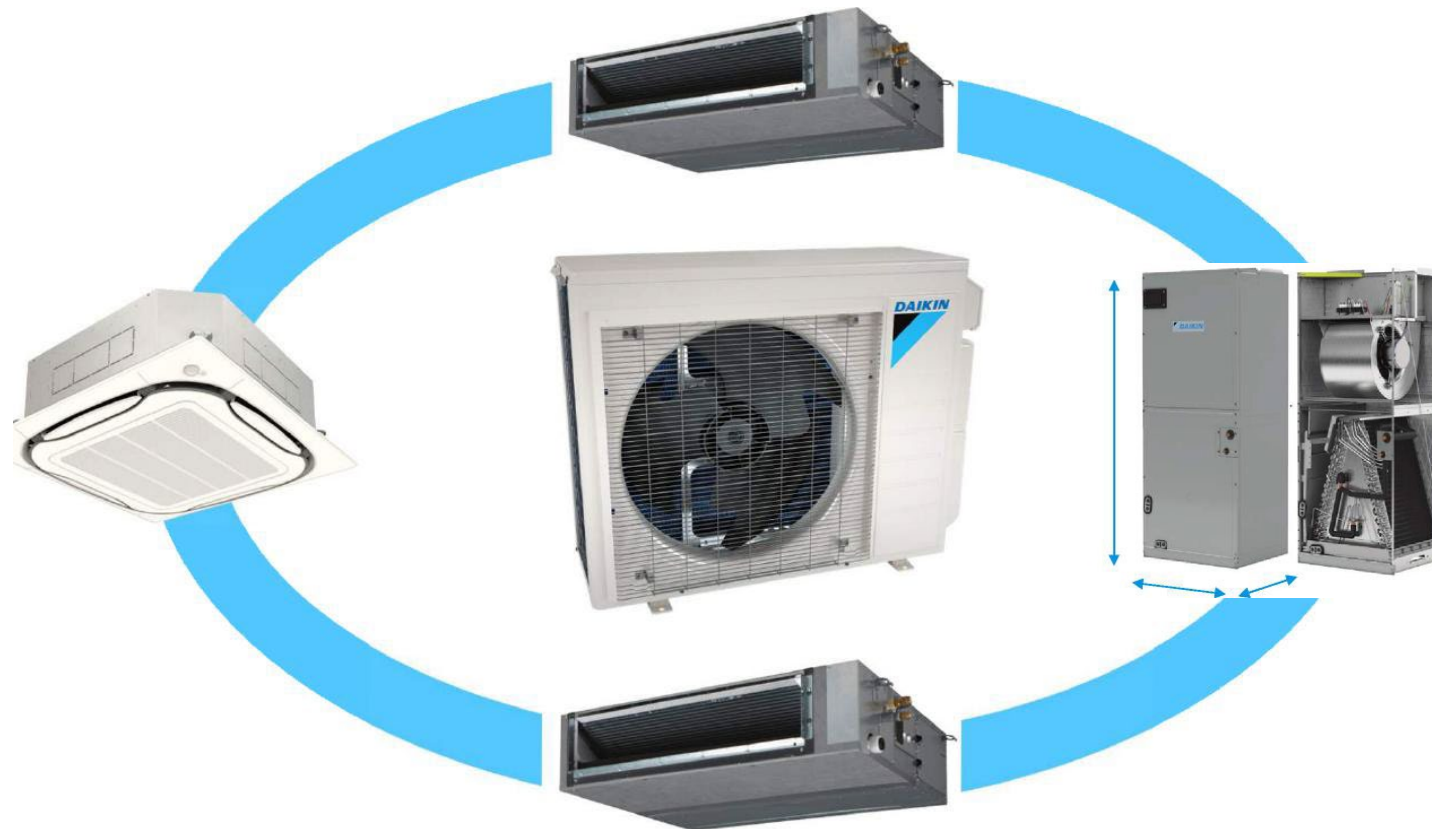

New Nomenclature

R	X	T	A	*	*	AA	V	J	U
---	---	---	---	---	---	----	---	---	---

R - 32 -

Major Design Change

F	X	*	A	*	*	AA	V	J	U
---	---	---	---	---	---	----	---	---	---

All products will transition
from **Q** **A** in the
model number to
represent change from

R-410A **R-32**

VRV Indoor Units – R32 Features

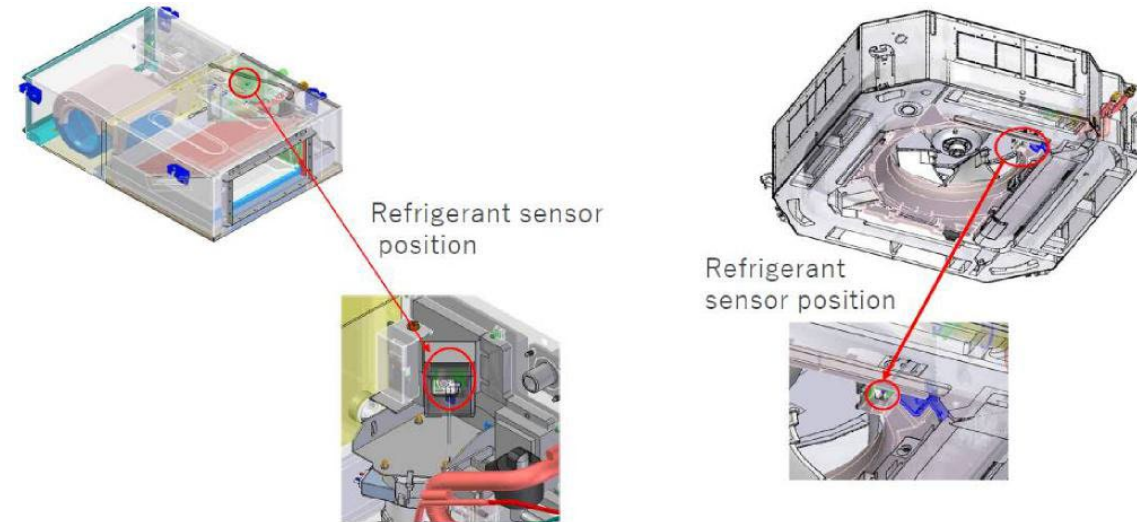

Leak Sensor and Alarm

- † Factory installed solution to meet code - provided straight from the factory and tested
- † Simplicity to installer/designer – correct sensor already installed and sequence ready to go
- † Easy to access from side panels and easily replaceable
- † Alarm displayed on remote controllers

VRV Indoor Units – R32 Features



Signal Output to External Devices

- † Dry contacts activates upon leak detection (via optional relay PCB)
- † Easy to connect to alarms, ventilation, exhaust, BMS systems
- † Can address custom requirements for specific applications such as Hotels, Schools, Government buildings – specific codes
- † Peace of mind to customer
- † Ventilation/damper – address rooms that need ventilation as a mitigation measure

VRV Indoor Units – R32 Features

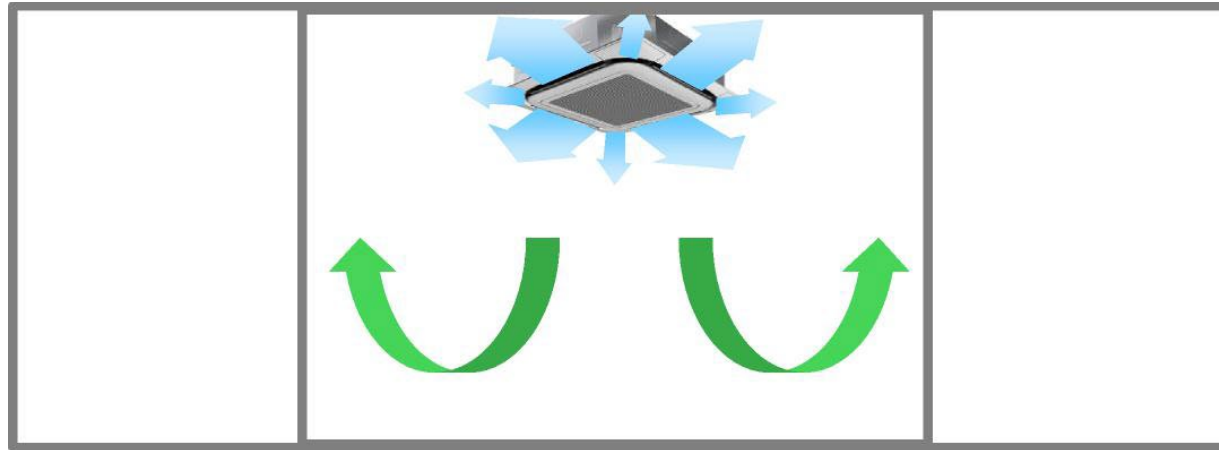

Full Circulation Mode – **DISPERSE**

- † Offers added Design flexibility
- † Activates upon leak detection *[offered as Std on all VRV IDUs]*
- † Forces IDU into special mode to **DISPERSE** leaked refrigerant
- † Effectively doubles the EDVC limit *[$0.5 \times LFL = 9.6 \text{ lbs}/1,000 \text{ cu.ft}$]*
- † Solution for tight spaces that would fall outside the limit

VRV Indoor Units – R32 Features



R32 Indoor Units (FXFA, FXSA, FXMA, FXTA) will have the same overall dimensions

- ✦ Easy design change to R-32 with same IDU spec as current + Added safety functions
- ✦ Same ductwork connections, ceiling cutouts, space required, maintenance clearances
- ✦ Same CFMs as prior units

FXFA – 3x3 Round Flow Cassette

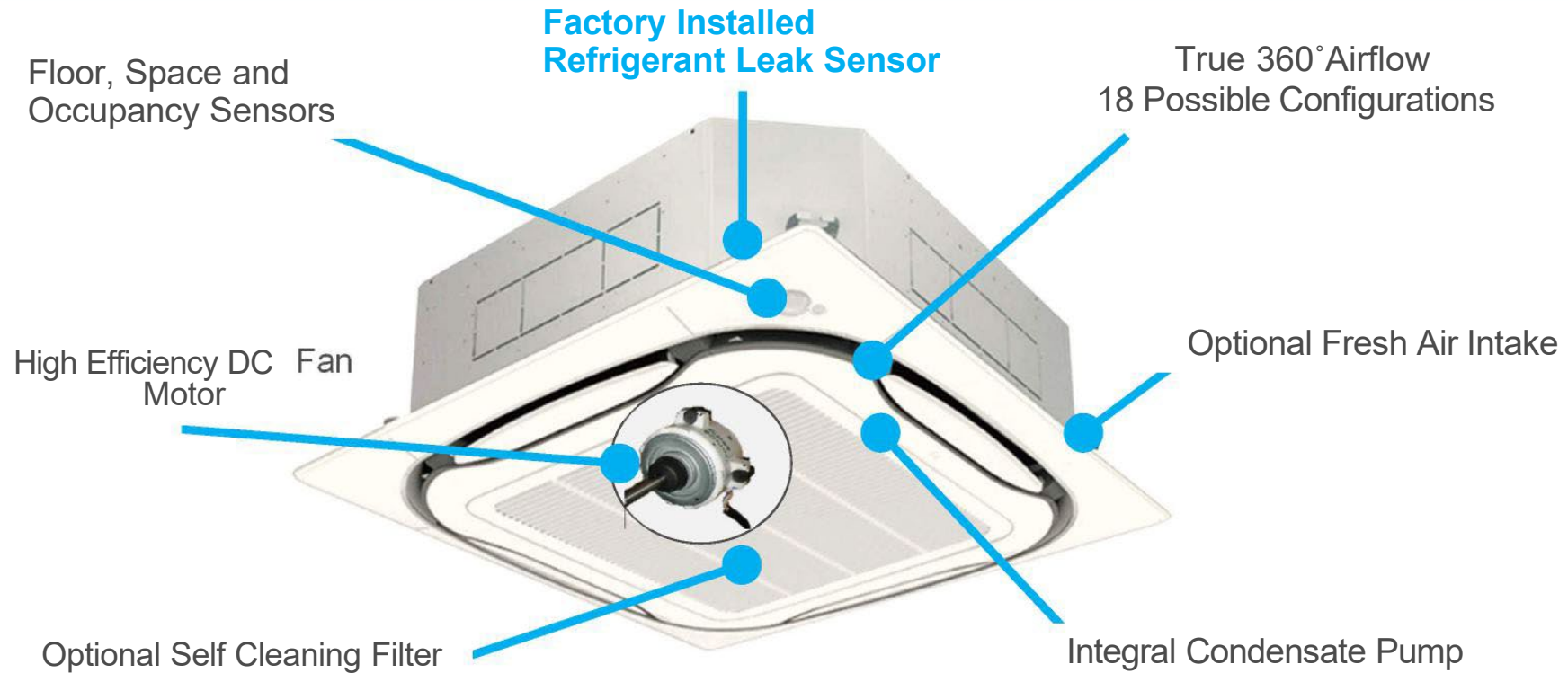

VRV Indoor Units - FXFA

Optional Self Cleaning Filter

Convenient and reduces maintenance costs for filter changing

Filter is kept clean which can be more effective in removing particulate matter

Automatically alerts occupants with a light for when duct container needs to be emptied and hence reduces the chance for dirty filters being kept in the unit and forgotten.

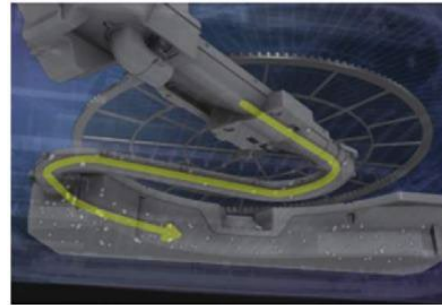

Dust from the air filter brush is deposited into the dust collection container during the fully automatic self-cleaning process.

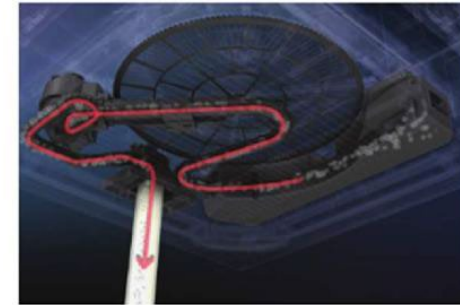

When indicated, the dust container in the unit is easily emptied with a standard vacuum cleaner.

True 360 Airflow

Reduced air drafts and improved comfort vs 4 way blow options

Fewer dead spots in the conditioned space

8 different flow patterns possible

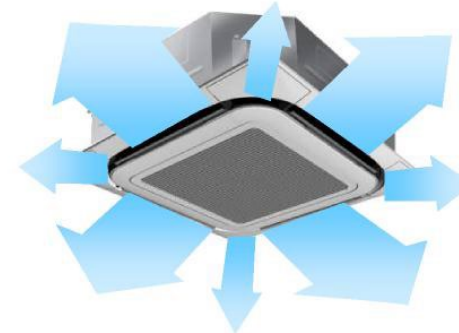

FXMA and FXSA – HSP Ducted Unit and MSP Ducted Unit

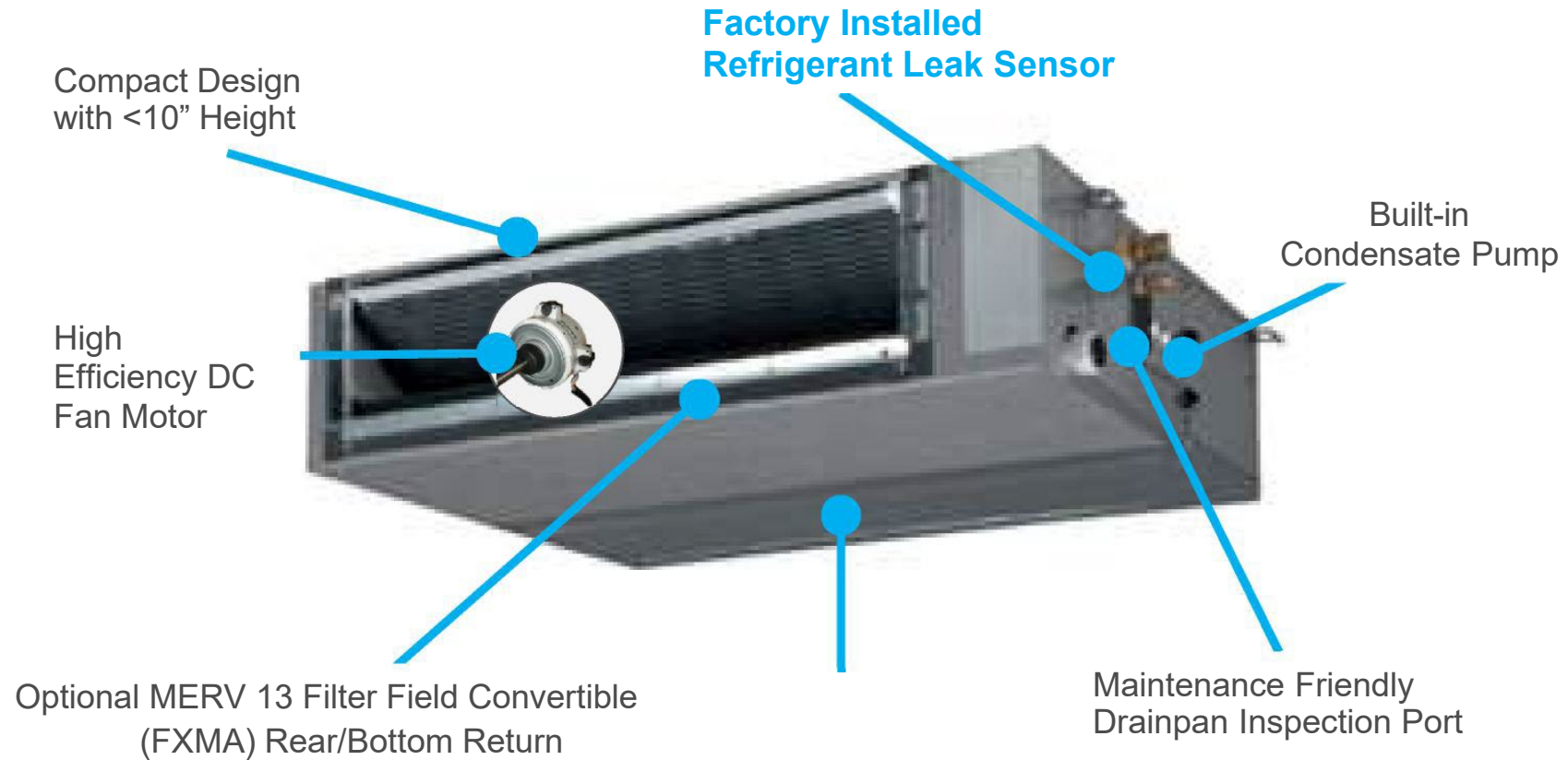

FXSA and FXMA Features – Condensation Reduction



Condensation Prevention through Discharge Air Control

- †Intelligently keeps discharge air temperature above the dew point temperature of the room
- †Minimizes condensation at the duct supply grilles
- †Fewer complaints from customers – end users typically point at the system
 - †Condensation could also drop on the floor creating hazards. This function minimizes this risk and nuisance (restaurants, grocery stores for example)
- †Prevents mold growth cause by condensation at grilles

FXSA and FXMA Features – Auto Airflow Adjustment



Automatically Adjust Fan to Deliver Near Nominal CFM

- ✦ Reduces Testing Adjusting and Balancing time and reduces cost
- ✦ System up and running quicker
- ✦ Can be reconfigured as needed if any changes implemented in field
- ✦ Especially useful in cases where many units are installed on a large project

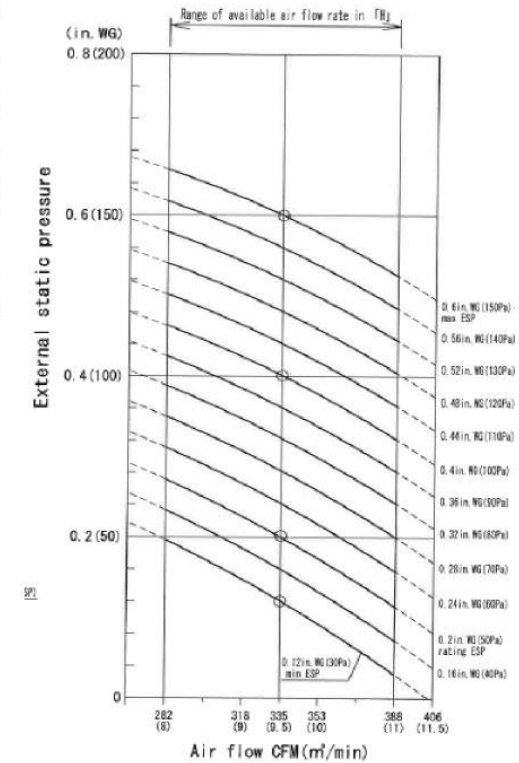

FXTA – Multi Position Ducted Unit

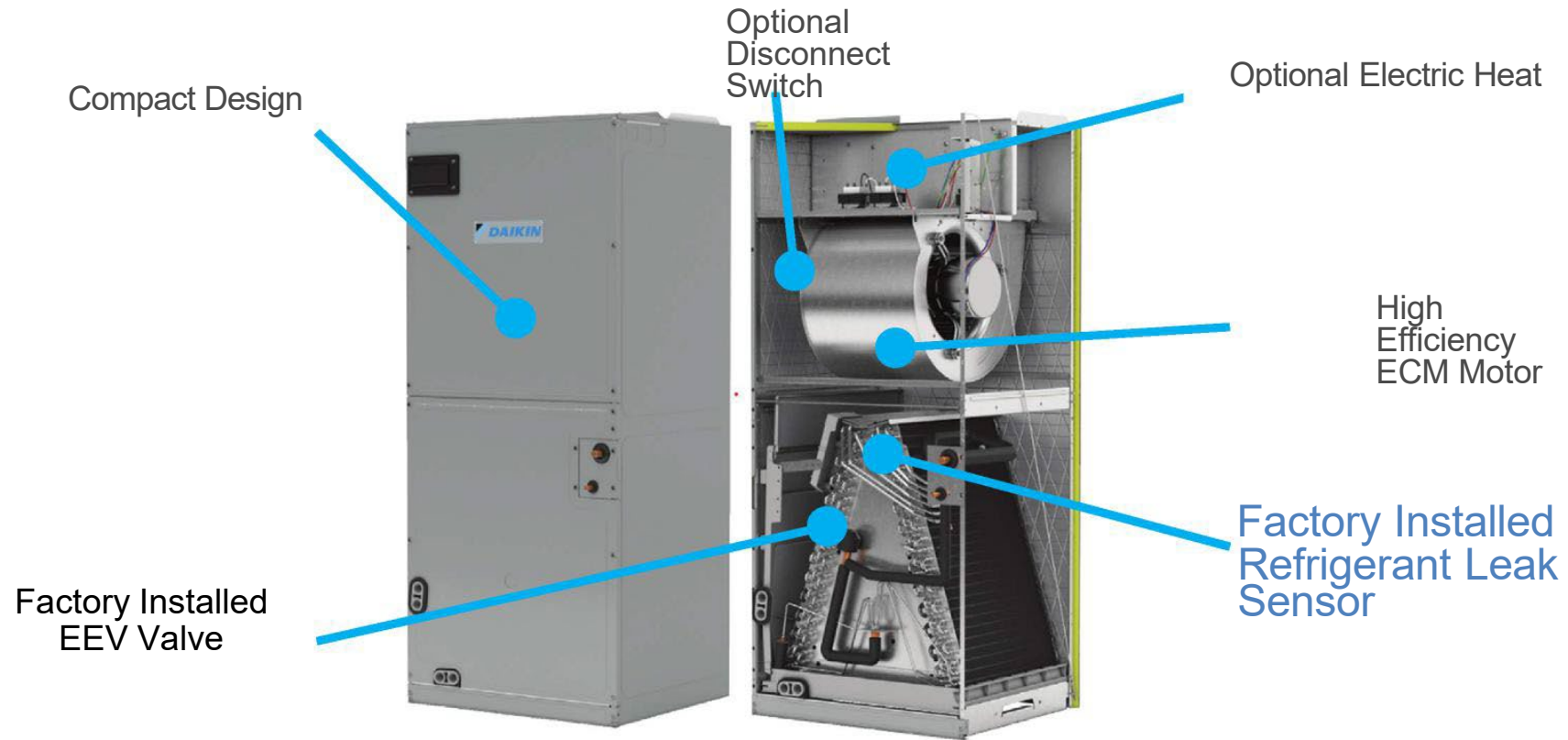

VRV-S Outdoor Unit - RXTA

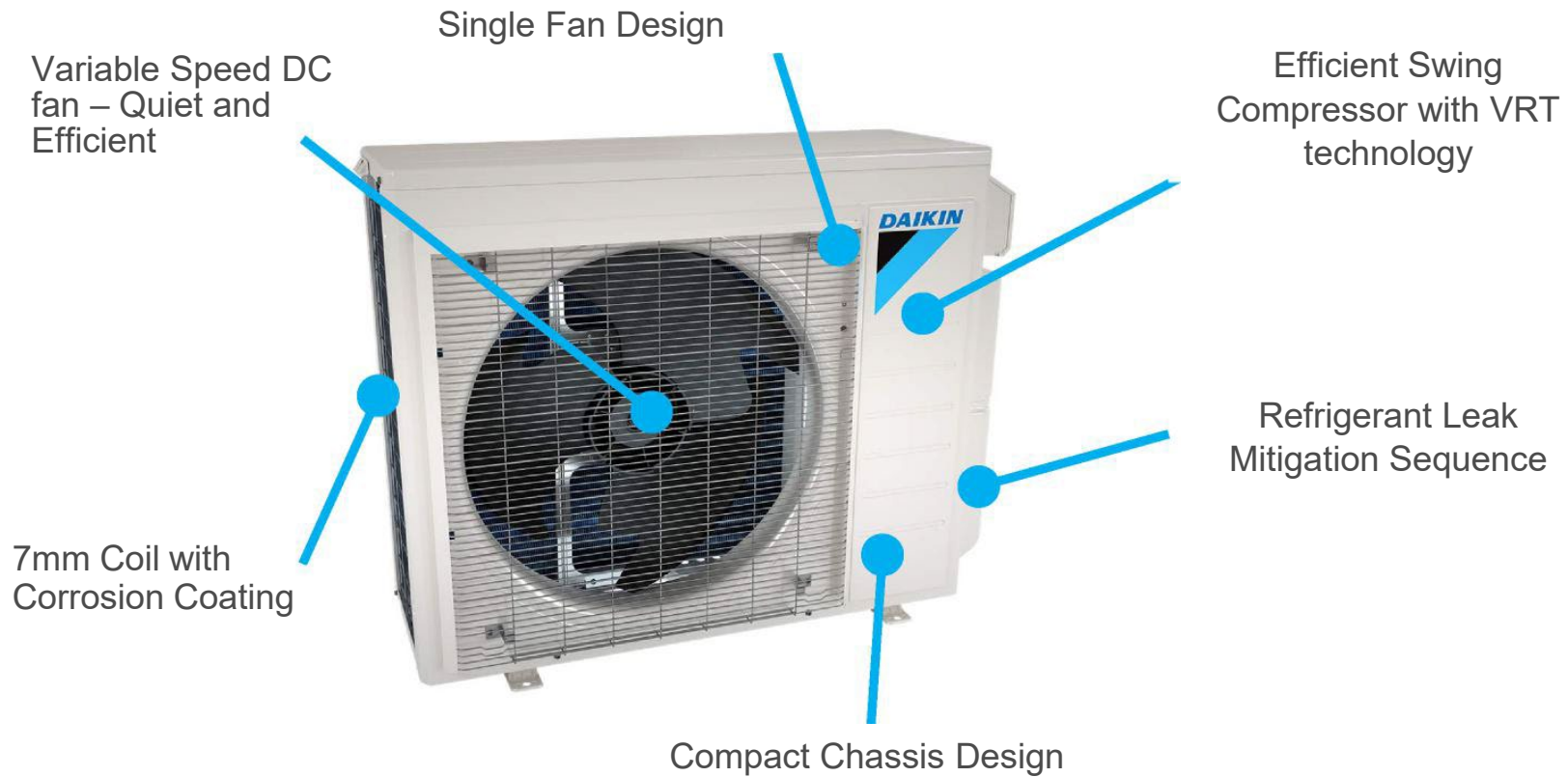

VRV-S Features – Larger Piping Diameter Setting

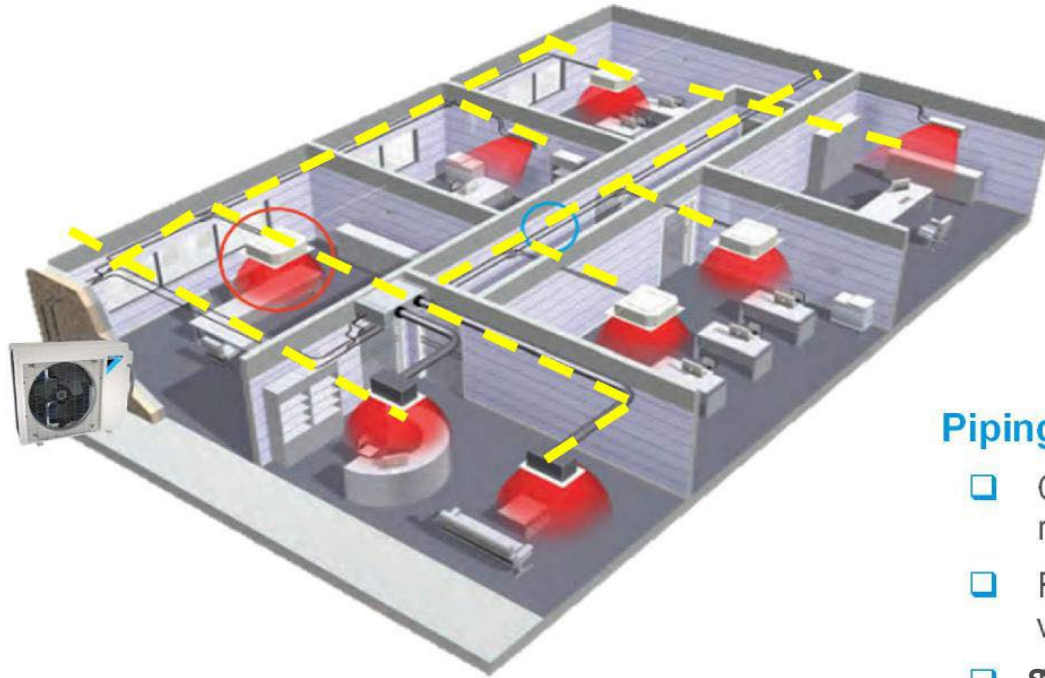

Piping Size Retrofit Field Setting

- Cases where 410A systems are being replaced and piping can be reused
- Field setting allows using 410A piping sizes with the new R32 equipment
- Significant material and labor cost savings



Thank you